

# OCAM

**4X4**  
**ACCESSORIES**

## INSTALLATION INSTRUCTIONS

PART NUMBER: SSE2-SILVERADO-19

APPLICATION: SILVERADO / SIERRA 2019-2022 (SSE2-SILVERADO-19)

FITTING TIME: 4 hours



OCAM 4x4 Accessories  
31 Shirley Way, Epping, VIC 3076  
Telephone (03) 9357-0306  
Email: [hello@ocam.com.au](mailto:hello@ocam.com.au)  
ABN: 33166112278

## IMPORTANT INFORMATION

- Always wear safety glasses and hearing protection.
- Make sure work area is kept clean at all times.
- Check that all components, as listed, are present.
- Thoroughly read all instructions.
- This product or its fasteners must not be modified in any way.
- These instructions are accurate as at the revision date and do not take into account any changes made by the vehicle manufacturer to vehicle design after the revision date, or other accessories that are or have been fitted to the vehicle.
- It is the responsibility of the installer to confirm correct operation/clearance of all components.
- All holes drilled must have all burrs and swarf removed then coated with a suitable rust preventative paint.
- Ensure that all hardware is fastened to torque list as detailed in these instructions.
- On completion of the job, these instructions are to be given to the customer.

## PRODUCT CARE

- To maintain the appearance of the product, wash and dry regularly using a quality car wash.
- The product should be periodically checked for tightness.

Torque Settings		
BOLT SIZE mm	TORQUE Nm	TORQUE ft.lb
M5	5	4
M6	9	7
M8	22	16
M10	44	32
M12	77	57

## Tools Required

1. Socket set
2. Electric tape
3. Trim removal tool
4. Pliers

# COMPONENTS LIST



ECU

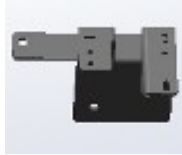

Front Iron Plate - 2 PCS

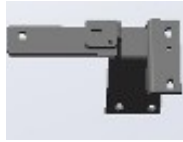

Middle Iron Plate 2 PCS

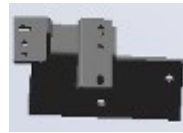

Rear Iron Plate - 2 PCS



Idler bracket - 4 PCS



Motor bracket - 2 PCS



M8x25 Flange bolt - 18



M6x25 socket cap bolt 12 PCS



M6 spring washer 12PCS



M8 washer 18PCS



M8 washer 18PCS



Wire harness: one set for motor power and signal



OBD Kit -1 Set



Plastic line 1 PCE



U-shaped washers 10 PCS



Cable ties 20PCS

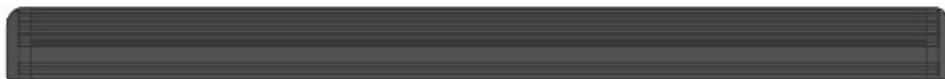

Side Steps 2PCS

# 1. Install ECU, OBD & Wiring



1. Open the engine compartment and located the battery



2. Remove the fuse from the supplied wiring harness



3. Connect the positive wire (red with fuse) to the vehicle battery-positive terminal. Ensure battery nut is tight.



4. Route the positive harness through to the left side of the cabin, as shown



5. Route the harness from the engine compartment to the chassis



6. Locate the harness from the cabin across the firewall to the chassis



7. Locate the OBD2 port underneath the driver side steering wheel column and connect the supplied OBD Patch connector.



8. Connect negative pole line to negative pole on the vehicle



9. Remove the scuff plate



10. Locate a fixing point for the ECU. E.g., this bolt shown which is on the left side, left front.



11. Fix the ECU using an M6 nut.



12. Lift out the carpet and route the motor harness to the chassis



13. Route the right side motor harness under the dashboard to the right side of the vehicle



14. Lift out the carpet on the right side and locate this rubber grommet



15. Route the right-side motor harness from the chassis to the cabin through this grommet



16. Plug all connectors together, re insert the fuse, lay the motor brackets on the ground, open and close the doors to test that the motor brackets are working correctly

Note: Use electric tape to protect all connectors. If the motor doesn't work, double check the previous steps or contact our customer care team for assistance

## 2. Install the left (USA-driver side) side bracket bases to the body

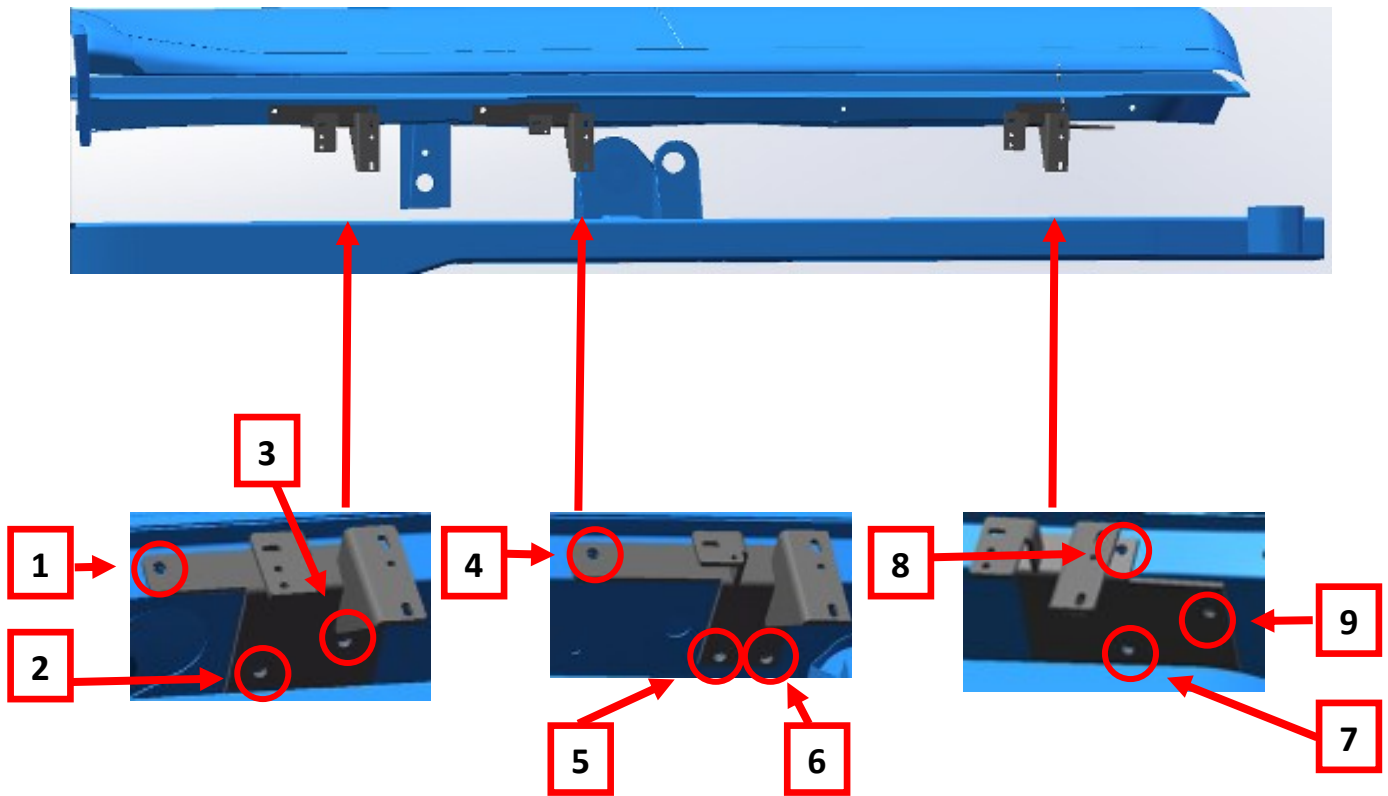

For 1-9, use M8x25 flange bolts and washers to install..

**Tighten all bolts.**

3. Install the left (USA-driver) side brackets to the brackets to the bases.

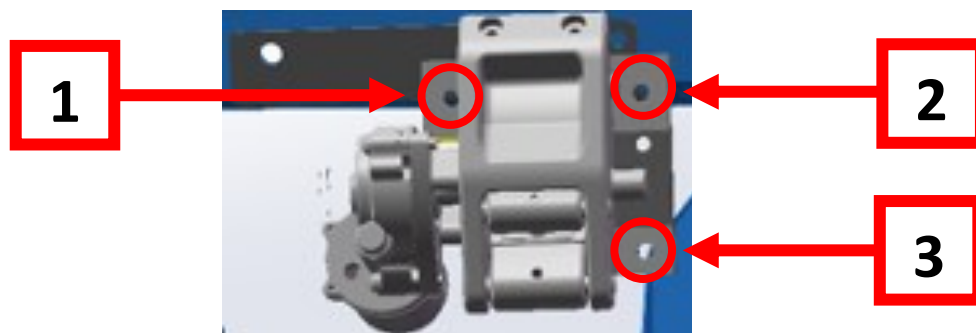
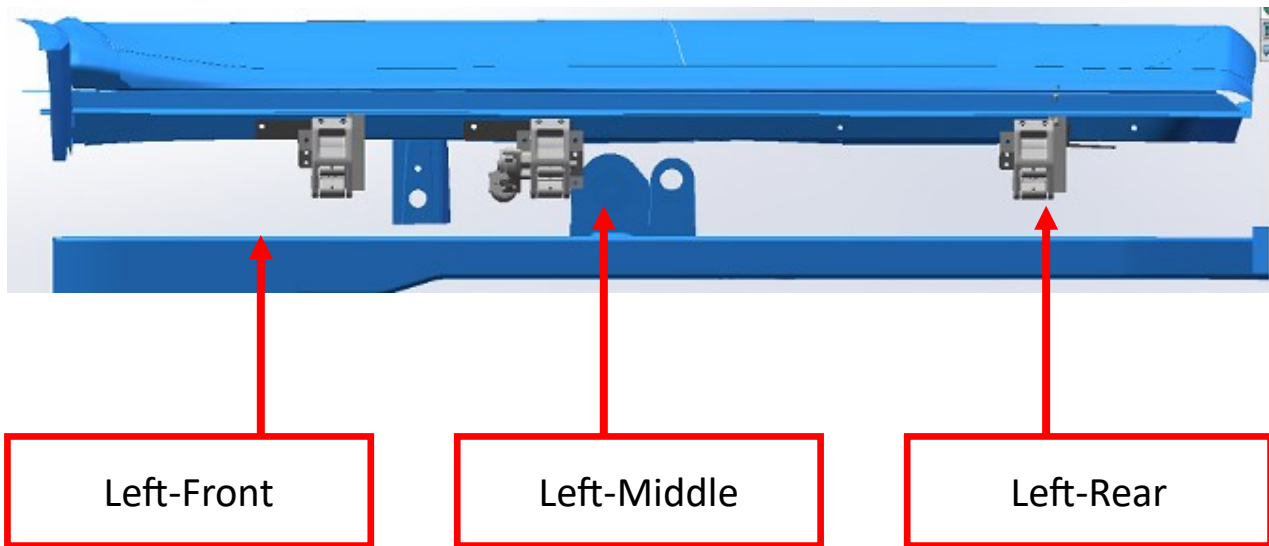

Fix 1.2.3. for each bracket with M8x25 carriage bolts and nuts. Same for the other two brackets.

**Important: do not tighten nuts yet, keep them a little loose so that the brackets can be adjusted**

4. Install the side steps. Both side are done in the same way

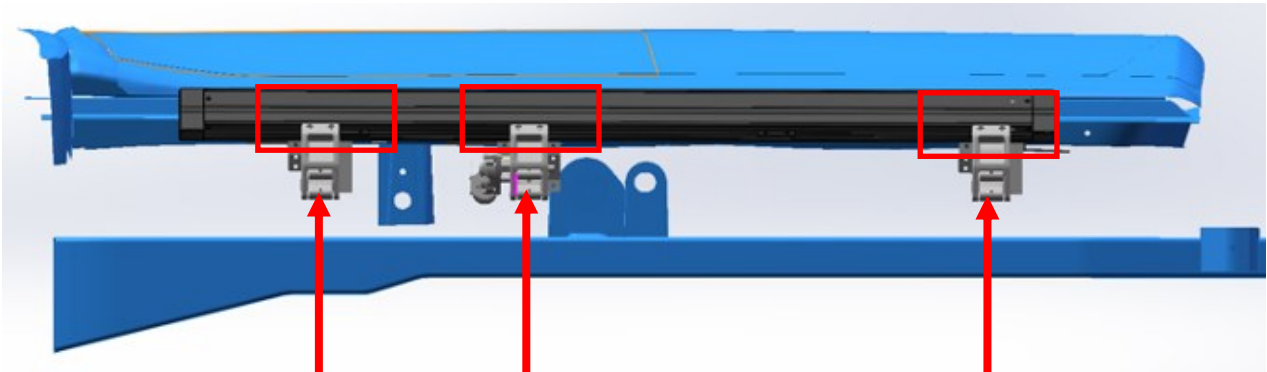

Use M6x25 bolts and M6 spring washers to fix side steps to the brackets.

**Tighten all bolts**

## 5. Test and adjust/balance.

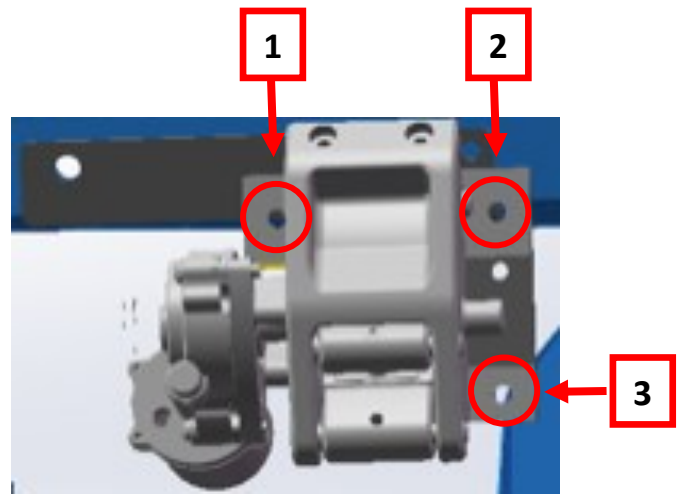

Open and close the doors to check that the steps work correctly. Ensure the steps are free of any obstruction. As they move up and down they will adjust to the correct position themselves. If needed, push the step tightly to match the vehicle chassis when retracted.

Tighten all bolts on the 6 brackets. If the side steps are out of alignment, use the U-shaped washers to adjust them.

Install the other side in exactly the same way. Installation is now complete!

## **Automatic power deployment:**

The side steps will extend down and out when the door is opened.

## **Automatic stop:**

If an object is in the way of the moving side step, the side step will automatically stop. To reset, clear any obstruction, then simply open and close the door to resume normal operation.

## **Manually set in the deployed (OUT) position for access to the roof:**

Stand on the side step while closing the door. To resume normal operation, open and close the door.

## **Maintenance:**

In adverse conditions, debris such as mud, dirt, and salt may become trapped in the side step mechanism, possibly leading to unwanted noise. If this occurs, avoid spraying the motors directly and after washing, apply silicone spray lubricant to the hinge pivot pins.

Caution! Keep hands and feet away when the side steps are in motion.

Thank you for choosing the OCAM Electric Side Steps. Enjoy!!